

ANNUAL ACTIVITY REPORT

&

PROGRAMME – 2013-2014

OF

**DIRECTORATE OF FACTORIES & BOILERS,
ODISHA**

1.0 Introduction :

The Directorate of Factories & Boilers, Odisha works under the administrative control of Labour & ESI Department, Govt. of Odisha. This Directorate is entrusted with the responsibility of implementation of various Acts, Rules and Regulations as mentioned below relating to Safety and Health of the industrial workers and protection of plant, process, machineries and equipments from accidental damage.

A) Enforcement of Central Acts / Regulations

1. Factories Act, 1948
2. Boilers Act, 1923
3. Indian Boiler Regulations, 1950

B) Enforcement of Rules under the Acts

i. State Rules

1. Orissa Factories Rules, 1950
2. Orissa Factories (Control of Major Accident Hazard) Rules, 2001
3. Orissa Boiler Rules, 1971

ii. Central Rules

1. The Boiler Attendants' Rules, 2011
2. The Boiler Operation Engineers' Rules, 2011

C) Additional Responsibilities

1. The Building & Other Construction Workers (Regulation of Employment and Conditions of Services) Act, 1996 [BOCW Act] Chapter-VI (Hours of Work, Welfare Measures & Other Conditions of Service of Building Workers) and Chapter-VII (Safety and Health Measures) only.
2. Orissa Building & Other Construction Workers (Regulation of Employment and Conditions of Service) Rules, 2002 (Only the provisions under Chapter VI & VII of BOCW Act).
3. Chemical Accidents (Emergency Planning, Preparedness and Response) Rules, 1996 (limited provisions only) under Environment (Protection) Act, 1986.
4. Manufacture, Storage & Import of Hazardous Chemical Rules, 1989 (limited provisions only) under Environment (Protection) Act, 1986.

2.0 Organization structure:

This Directorate is headed by Director of Factories & Boilers under whom two Joint Directors of Factories & Boilers, one Deputy Director of Factories & Boilers (Safety), one Assistant Director of Factories & Boilers (Headquarters), one Assistant Director of Factories & Boilers (Safety) and one Assistant Director of Factories (Medical) are functioning at Headquarters. Besides, for enforcement in the field, there are seven Divisions headed by Deputy Directors of Factories & Boilers and twenty-two Assistant Directors of Factories & Boilers working under their control at different Headquarters throughout the State.

The organization structure is furnished herewith.

Organization Chart

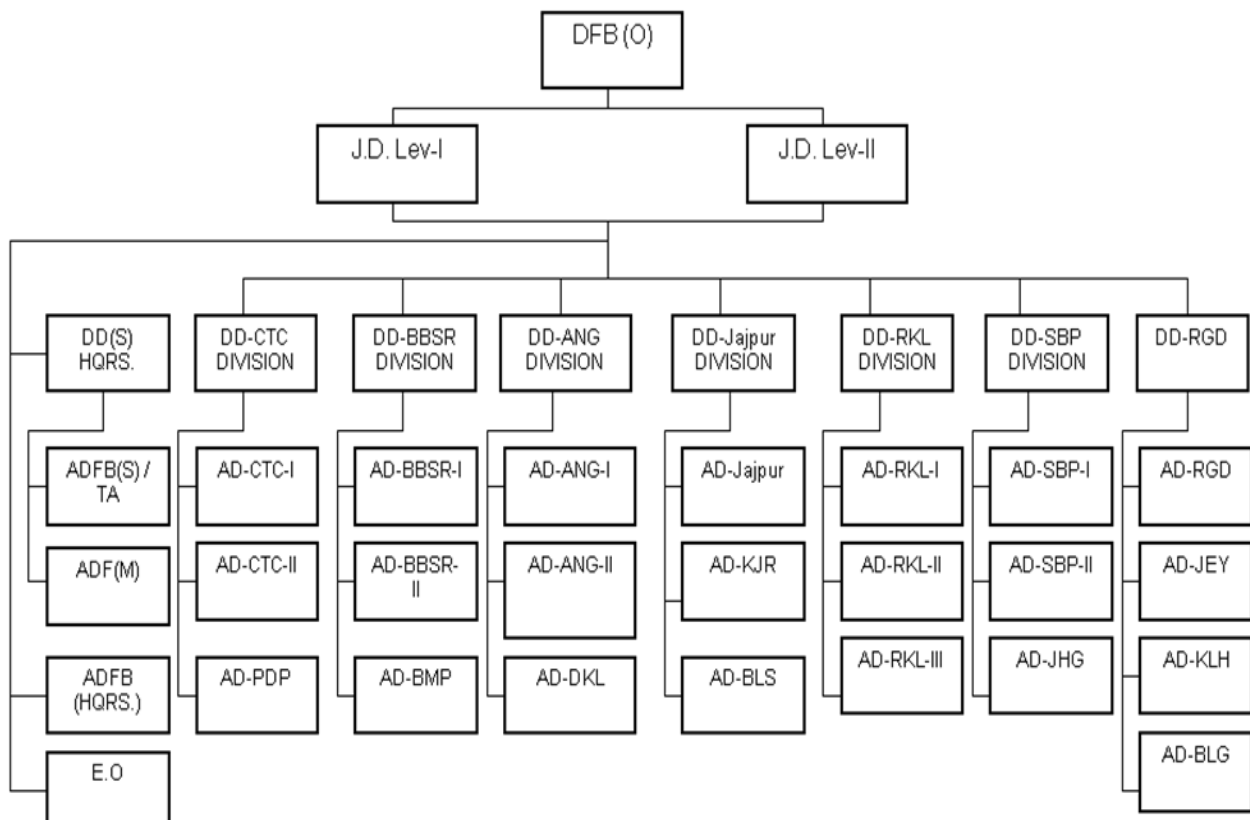

3.0 Aim and objective :-

The basic aim and objective of the Directorate is to enforce the above legislations for securing safety, occupational health, work environment, welfare and working condition in factories. With the advent of new technology, innovation and modernization, the work of this Directorate has increased multi-fold over the last decade. Further, several chemical factories have come up in the State handling hazardous and toxic substances which has been a challenge for the enforcement mechanism to handle such complex matters in enforcement of Industrial Safety and Health. The Directorate is consistently putting its untiring effort to safeguard life and property of industrial workforce.

The Directorate is bestowed with the added responsibility of developing Disaster Management system in Major Accident Hazard as well as Accident-prone factories of the State to prevent and mitigate Chemical and Industrial Disasters.

Besides, the legislations regulating Safety in Design, Manufacture, Quality assurance, Installation, Erection, Operation, Repair, Maintenance and Certification aspects of Boiler plants along with its connected Pipelines and equipments thereof is also a major responsibility assigned to the Directorate.

4.0 Programmes :

For proper enforcement and implementation of the existing Acts and Rules, the following programmes have been devised by the Directorate.

A. HEADQUARTERS

- Scrutiny of plans, technical specifications and documents along with Safety & Health Policy, Material Safety Data Sheet, Process Flowchart, On-site Emergency Plan, etc. for the purpose of Approval, Registration and Licensing of factories under the Factories Act, 1948

- Scrutiny of design, drawings, technical specifications and documents in respect of boilers, steam pipelines and related equipments under Indian Boiler Regulations for the purpose of registration and certification.
- To review and analyse accidents and dangerous occurrences and suggest remedial measures.
- To assess performance of Safety Officers deployed by different factories for acceptance under the Factories Act.
- To review On-site Emergency Plan and detailed Disaster Control measures and assess its workability for acceptance by Authority.
- To carry out technical competency and assessment of persons / Institutions for recognition as Competent Person in respect of Stability of Buildings and Structures, examination and testing of Hoists, Lifts, Cranes and other Lifting Machines, Pressure vessels, Piping and plant thereof, Confined space containing Dangerous fumes, Ventilation systems, Process of sand blasting, Asbestos processing, etc.
- To ensure medical examination and surveillance of industrial workers exposed to hazardous work environment.
- To ensure monitoring of work environment in different processes involving dust, fume, hazardous chemicals, noise, etc.
- To assess Safety and Health Management System in different factories of the State.
- To scrutinize Safety Audit Reports and ensure compliance.
- To assess technical competence of firms / persons for recognition as Boiler Manufacturer / Erector / Repairer under Indian Boiler Regulations, 1950.

- To conduct Boiler Operation Engineer / Boiler Attendant / Welder Certification Examination for the purpose.
- To conduct various promotional programmes such as training, seminar, workshop on safety and occupational health.
- To carry out periodic review and performance assessment of field officers.

B. FIELD (Zonal ADF&Bs and Divisional DDF&Bs)

- To inspect all Factories at least once in a year.
- To impart special thrust on all accident-prone and 2(cb) category Factories (i.e. the factories involving hazardous processes as defined in First Schedule).
- To ensure compliance by periodic check-up and initiate appropriate action against the recalcitrant occupiers and managers.
- To inspect Boilers along with the attached steam pipelines and equipments thereof periodically and also when needed.
- To provide advice on proper repair and maintenance of boilers as and when required in the event of detection of defect or failure.
- To investigate accidents and dangerous occurrences and take appropriate action.
- To enquire into the complaints and take remedial measures.
- To detect registrable-unregistered factories for registration and licensing under Factories Act.
- To detect crude steam generating devices used in factories and other places and take appropriate action for its dismantling.

5.0 Statistics on different activities :

A statement with details of information under both Factories Act and Boilers Act during the year and the preceding four years is furnished below.

5.1 Registered Factories

Year	Total number of registered factories
2009-10	3285
2010-11	3369
2011-12	3512
2012-13	3611
2013-14	3742

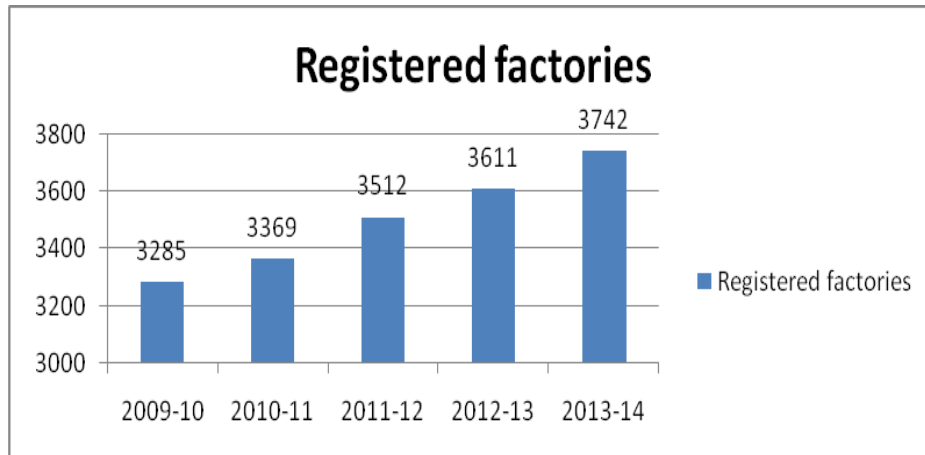

5.2 Registered Boilers

Year	Total number of Registered boilers
2009-10	1502
2010-11	1614
2011-12	1714
2012-13	1810
2013-14	1979

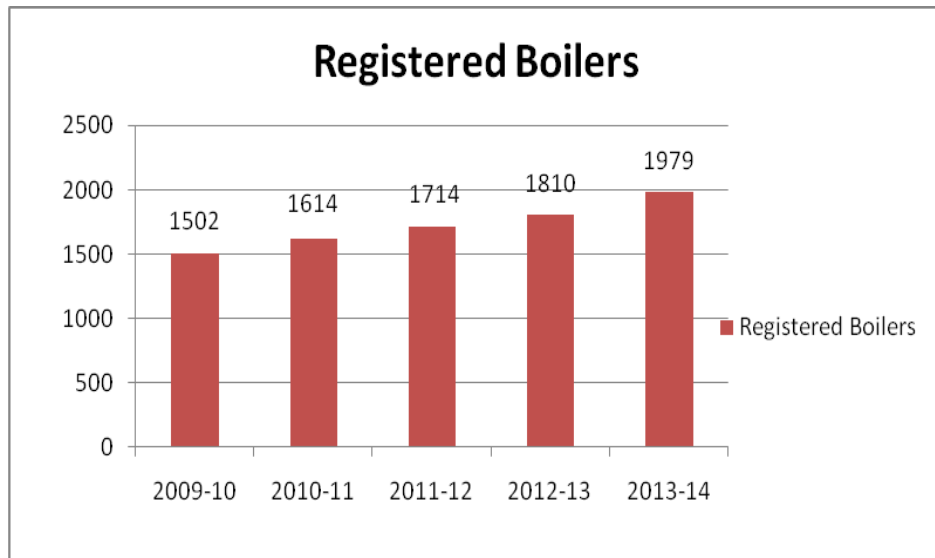

5.3 Training for Industrial Workers

Year	Number of training programmes conducted	No. of persons benefited
2009-10	1993	82,037
2010-11	2273	92,739
2011-12	2564	1,01,981
2012-13	2791	1,19,367
2013-14	2825	1,28,345

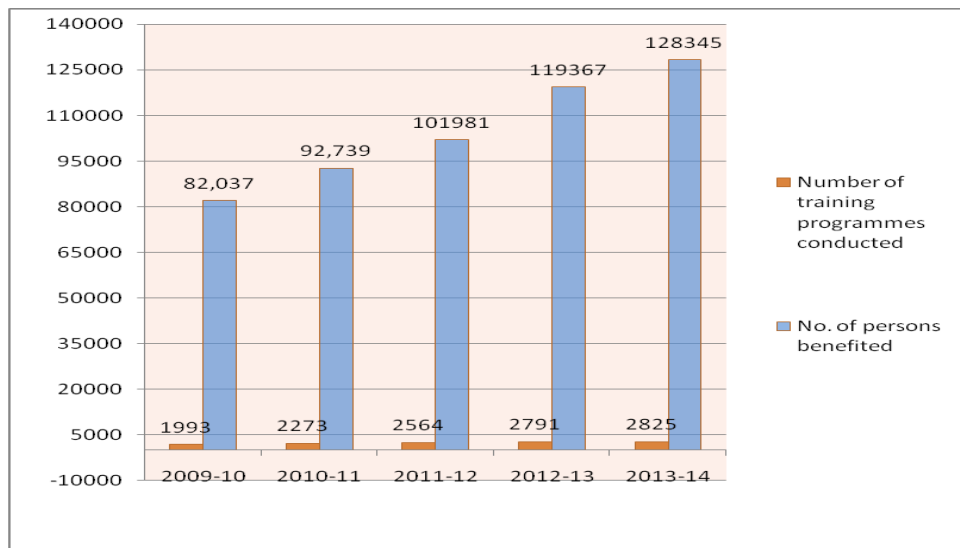

5.4 Health Check-up

Year	Total no. of workers undergone health Check-up
2009-10	1,02,249
2010-11	1,55,504
2011-12	1,63,239
2012-13	1,98,981
2013-14	2,11,947

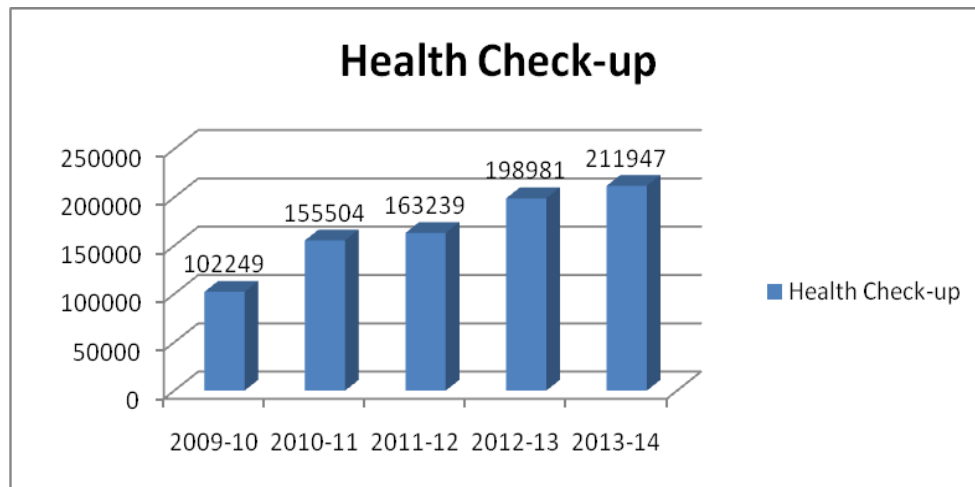

5.5 Assessment of Safety Officer

Year	No. of Safety Officers assessed
2009-10	11
2010-11	25
2011-12	33
2012-13	77
2013-14	110

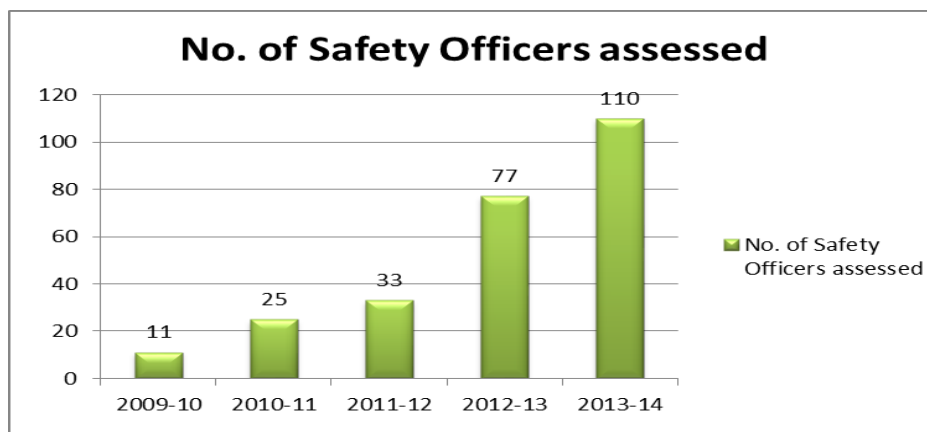

5.6 Review of Safety, Health & Environment (SHE) system of Factories

Year	No. of SHE system reviewed
2009-10	09
2010-11	20
2011-12	29
2012-13	29
2013-14	33

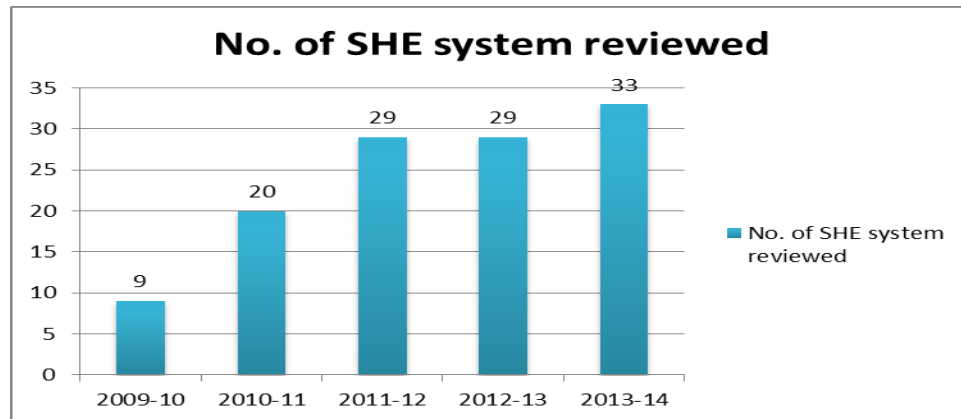

5.7 Workability of On-Site Emergency Plans

Year	No. of On Site Emergency Plans reviewed
2009-10	11
2010-11	20
2011-12	21
2012-13	31
2013-14	33

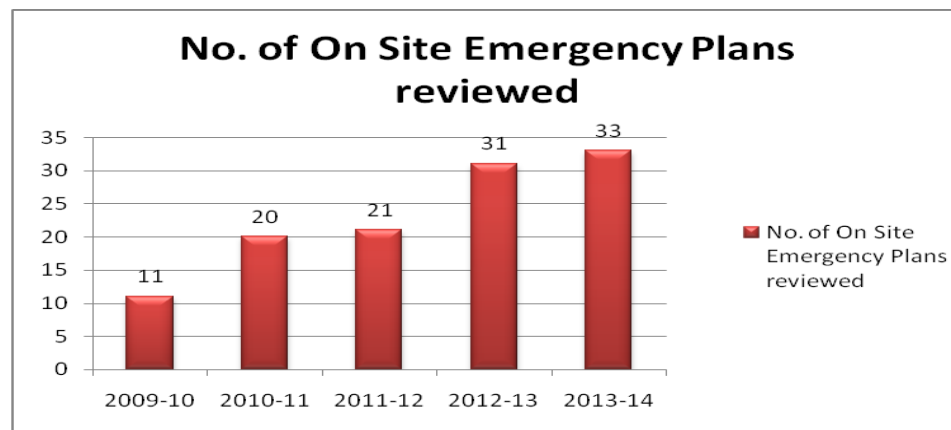

5.8 Work Environment Monitoring

Year	No. of Work Environment Monitored / Assessed
2009-10	24
2010-11	45
2011-12	65
2012-13	72
2013-14	46

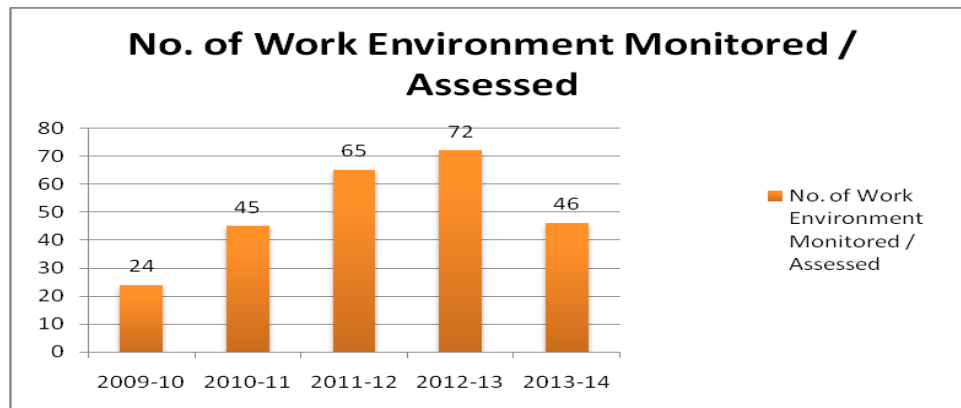

5.9 Fatal Accidents

Year	No. of fatalities
2009-10	121
2010-11	90
2011-12	66
2012-13	70
2013-14	62

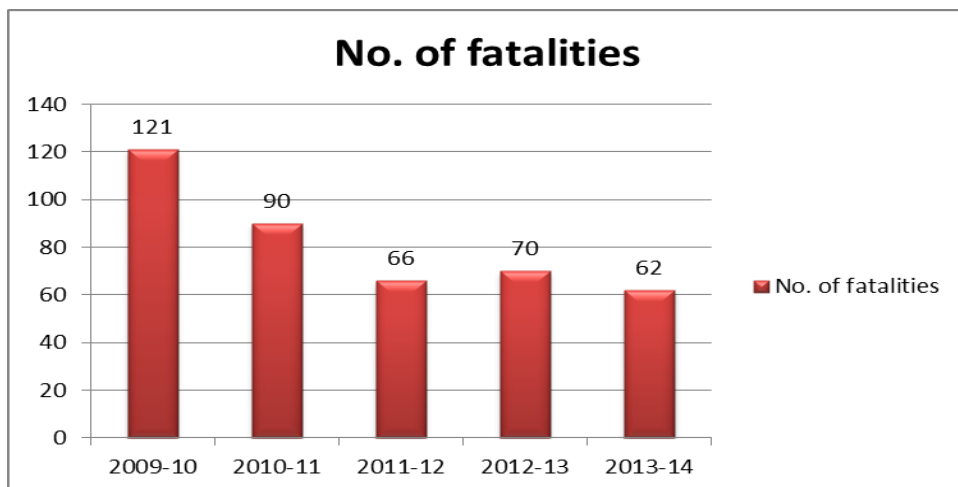

5.10 List of Prosecutions Filed

Year	No. of Prosecutions filed
2009-10	82
2010-11	132
2011-12	212
2012-13	196
2013-14	127

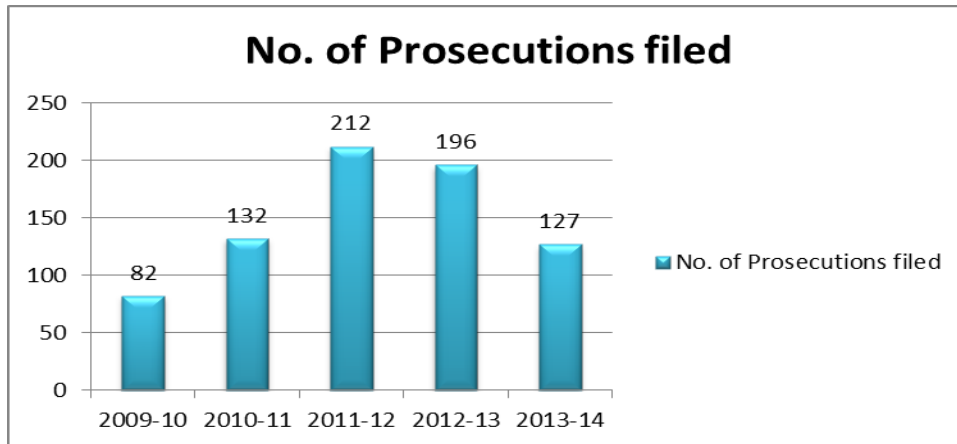

5.11 Revenue Receipt

(Fees collected under both Factories Act and Boilers Act and Rules framed thereunder towards scrutiny and approval of plans, design drawings, registration, licensing, recognition of competent persons, enrolment of boiler manufacturer, steam pipeline erector, repairer, examination fee for conducting BOE and BACC examination, etc.)

Year	Receipts in Rupees (Lakhs)
2009-10	431.62
2010-11	585.51
2011-12	568.02
2012-13	621.6
2013-14	611.76

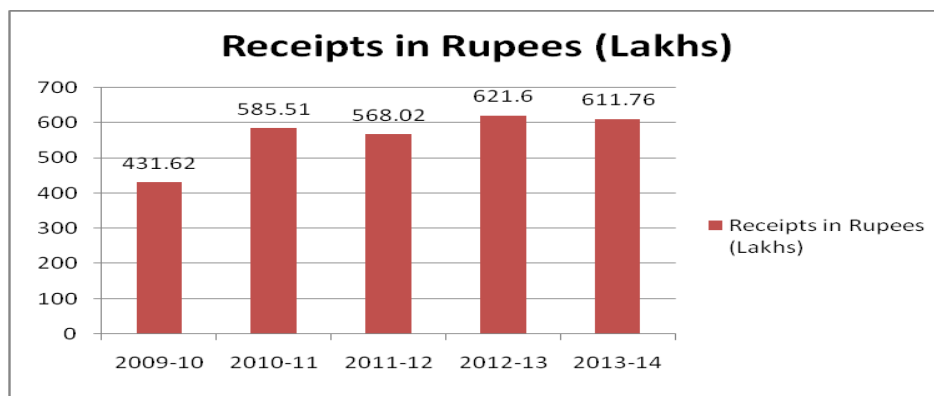

6.0 Action initiated by the Directorate:

- Identified accident-prone factories of the State and circulated the list to all officers of the Directorate for proper enforcement and special attention in improvement on safety and accident prevention.
- Frequent review of Safety Management System of hazardous factories done by a team of officers.
- Prohibition orders and improvement notices served on detection of imminent danger to human life or safety and immediate compliance ensured.
- All cases of fatal accidents reviewed by a team of officers at Head office in presence of the senior technical officers of the management and action plan formulated to avert similar accidents.
- All On-site Emergency Plans scrutinized, reviewed and assessed by a team of officers of the Directorate and the workability of such plan ensured.
- Strict instructions issued to conduct mock drill in presence of field officers and improvement brought in the system.
- The field officers are activated to conduct the meeting of District Crisis Group in consultation with the Collector and District Magistrate concerned.
- Performance of Safety Officers assessed before acceptance.
- Some of the accident-prone factories were inspected by the Director of Factories & Boilers and other senior officers and action taken for improvement.

7.0 Major data on achievement of the Directorate during 2013-14 :

In addition to improvement in normal functioning of the Directorate with faster approval of statutory matters, the following achievements were made during the year 2013-14.

- Due to consistent action by the officers of the Directorate with special focus on reduction of accidents, the rate of accidents have come down to about 50% within a span of five years as compared to previous years.
- Departmental Disaster Management Plan was prepared for the first time and submitted to the Additional Chief Secretary-cum-Managing Director, Odisha State Disaster Mitigation Authority. The Departmental Disaster Management Plan after approval by the Authority has been uploaded in the Government portal.
- After explosion at Blast Furnace of M/s. Bhushan Steel Limited, Dhenkanal on 13.11.2013, a State level Seminar was conducted for the Integrated Iron & Steel Industries of the State involving experts in the field and several critical issues relating to Safety of Blast Furnaces were discussed in details.
- The meeting of the State Crisis Group was conducted on 18.01.2014 under the Chairmanship of the Chief Secretary, Odisha and action made for development of an effective system for management of chemical and industrial disasters.
- On receipt of early warning alert on cyclone '*Phailin*', preventive measures were adopted and effectiveness of safety system in factories located at Ganjam and Paradeep belts and other areas in the State were monitored before hand to prevent any untoward incident which yielded result.

- The Annual State Safety Award function meant for encouraging the factories and individuals for their outstanding contribution towards safety and occupational health was pending since 2010 for three years i.e. 2010, 2011 and 2012. In December 2013, the pending Award functions were done which encouraged and motivated the factory owners towards further improvement in safety and accident prevention.
- Instructions were given to the field functionaries to conduct periodic meeting of District Crisis Group in consultation with the Collector and District Magistrate and also to form Mutual-Aid Response Group at Disaster-prone areas.
- Actions made for appointment of competent supervisors in handling hazardous processes as per the legal provisions.
- Review and assessment of Safety Officers, Competent Persons, Safety and Health Policy, Safety Audit Reports, Emergency Planning, Fatal accidents and Dangerous occurrences, etc. relating to improvement in Safety Management System were made by a team of officers at Headquarters and improvement brought in this direction.